



Benjamin® Sheridan®

PNEUMATIC AIR RIFLES OWNER'S MANUAL

**Blue Streak® and Silver Streak® C9 Series .20 Caliber
and
397 Models, .177 Caliber and 392 Models, .22 Caliber**



**READ ALL INSTRUCTIONS AND WARNINGS IN THIS
MANUAL BEFORE USING THIS AIRGUN.**

FORM #544

CONGRATULATIONS!

Thank you for purchasing one of our precision made air rifles. We hope you share our enthusiasm for quality products.

Please read this owner's manual completely. And remember, this air rifle is not a toy. Treat it with the same respect you would a firearm. Always carefully follow the safety instructions found in this owner's manual and keep this manual in a safe place for future use.

If you have any questions concerning your new air rifle, please contact us.

Sincerely,

**Benjamin/Sheridan Corp.
RTS 5 & 20,
E. Bloomfield, N.Y. 14443**

⚠ WARNING: NOT A TOY. ADULT SUPERVISION REQUIRED. MISUSE OR CARELESS USE MAY CAUSE SERIOUS INJURY OR DEATH. MAY BE DANGEROUS UP TO 475 YARDS (435 METERS).

READ ALL INSTRUCTIONS BEFORE USING.

BUYER AND USER HAVE THE DUTY TO OBEY ALL LAWS ABOUT THE USE AND OWNERSHIP OF THIS AIRGUN.

THIS AIRGUN IS INTENDED FOR USE BY THOSE 16 YEARS OF AGE OR OLDER.

2

STEPS FOR SAFE SHOOTING

Step 1.	Learning the Parts of Your New Air Rifle	4
Step 2.	Operating the Safety	5-6
Step 3.	Pumping the Air Rifle	7
Step 4.	Loading and Unloading Pellets	8-9
Step 5.	Aiming and Firing Safely	9-11
Step 6.	Removing a Jammed Pellet.....	12
Step 7.	Maintaining Your Air Rifle	13-14
Step 8.	Reviewing Safety	15
Step 9.	Choosing Targets	15

Step 1. Learning the Parts of Your New Air Rifle

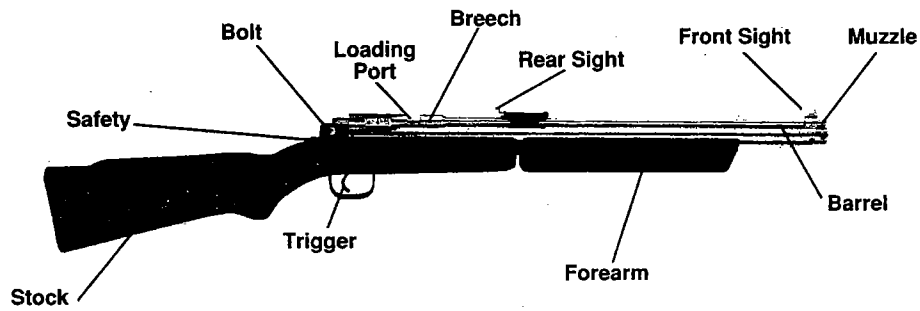

4

Step 2. Operating the Safety

NOTE: BE SURE THE RIFLE IS "OFF SAFE" BEFORE COCKING (Fig. 2). FAILURE TO FOLLOW THE PROCEDURE LISTED BELOW MAY RESULT IN JAMMING THE FIRING MECHANISM.

A. Cocking the Air Rifle

- Point the rifle in a safe direction.
- Push bolt handle up and then pull it all the way to the rear. (Fig. 1)
- Close the bolt by pushing the bolt forward and then downward into the locked position.

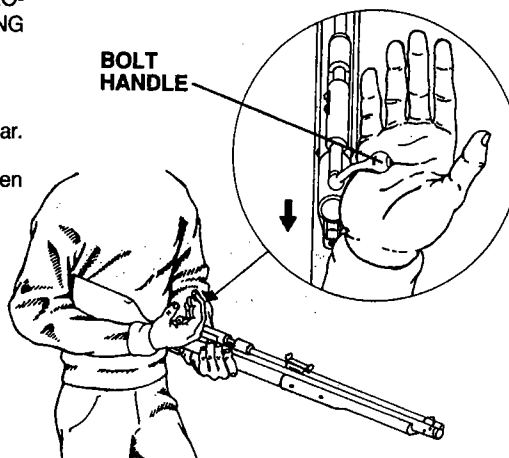

B. Putting the Air Rifle On Safe

⚠ WARNING: THE RIFLE MUST BE COCKED BEFORE YOU CAN PUT IT ON SAFE.

- To put the air rifle on safe, pull the safety all the way back with your thumb. The safety is not on unless it is pulled all the way back so the red dot is covered and the "S" is completely visible. (Fig 2)
- Even when the safety is on you should continue to handle the rifle safely. Don't point the rifle at anything you don't intend to shoot.
- To take the air rifle off safe, push the safety all the way forward. When you can see the red dot behind the safety the gun is off safe and ready to be fired. (Fig. 2)

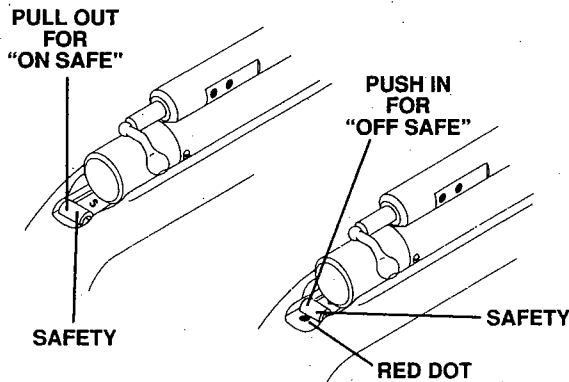

FIG. 2

6

⚠ WARNING: KEEP THE AIR RIFLE "ON SAFE" UNTIL YOU ARE ACTUALLY READY TO SHOOT. THEN PUSH IT TO "OFF SAFE."

Step 3. Pumping the Air Rifle

- Put the rifle on safe. (Step 2)
- Open the forearm all the way until it stops. (Fig. 3)
Close it with a smooth stroke using the heel of your hand. Don't pinch hand or fingers when the forearm closes. Keep your finger off the trigger while pumping.
- Be sure to use at least 2 pumps to prevent the barrel from jamming with a pellet.
- Do not twist forearm while pumping. Use straight strokes to prevent breakage.

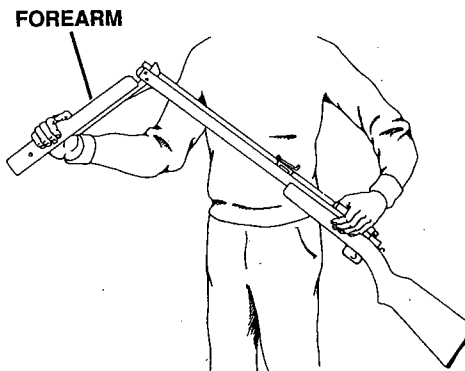

FIG. 3

⚠ WARNING: NEVER PUMP YOUR GUN MORE THAN EIGHT TIMES. OVERPUMPING GIVES ONLY A SLIGHT INCREASE IN POWER AND CAN CAUSE MAJOR DAMAGE TO YOUR GUN. PUMPING MORE THAN EIGHT TIMES MAY ALSO LEAVE A SMALL AMOUNT OF AIR IN THE GUN WHICH MAY ALLOW YOU TO FIRE A SECOND SHOT WITHOUT ADDITIONAL PUMPING.

