



**Model 397C .177 Caliber Pneumatic Air Rifle
OWNER'S MANUAL**



**READ ALL INSTRUCTIONS AND WARNINGS IN
THIS MANUAL BEFORE USING THIS AIRGUN.**

397C-515

9E4

CONGRATULATIONS!

Thank you for purchasing one of our precision made air rifles. We hope you share our enthusiasm for quality products.

Please read this owner's manual completely. And remember, this air rifle is not a toy. Treat it with the same respect you would a firearm. Always carefully follow the safety instructions found in this owner's manual and keep this manual in a safe place for future use.

If you have any questions concerning your new air rifle, please contact us.

Sincerely,

Benjamin Sheridan Corporation
Routes 5 & 20
East Bloomfield, New York 14443



WARNING: NOT A TOY. ADULT SUPERVISION REQUIRED. MISUSE OR CARELESS USE MAY CAUSE SERIOUS INJURY OR DEATH. MAY BE DANGEROUS UP TO 475 YARDS (435 METERS).

READ ALL INSTRUCTIONS BEFORE USING.

BUYER AND USER HAVE THE DUTY TO OBEY ALL LAWS ABOUT THE USE AND OWNERSHIP OF THIS AIRGUN.

THIS AIRGUN IS INTENDED FOR USE BY THOSE 16 YEARS OF AGE OR OLDER.

2

STEPS FOR SAFE SHOOTING

	Page
Step 1. Learning the Parts of Your New Air Rifle	4
Step 2. Operating the Safety.....	5
Step 3. Pumping the Air Rifle.....	6
Step 4. Loading and Unloading Pellets.....	7
Step 5. Aiming and Firing Safely	8
Step 6. Removing a Jammed Pellet	9
Step 7. Maintaining Your Air Rifle.....	10
Step 8. Reviewing Safety.....	12
Step 9. Choosing Targets	13

Step 1. Learning the Parts of Your New Air Rifle

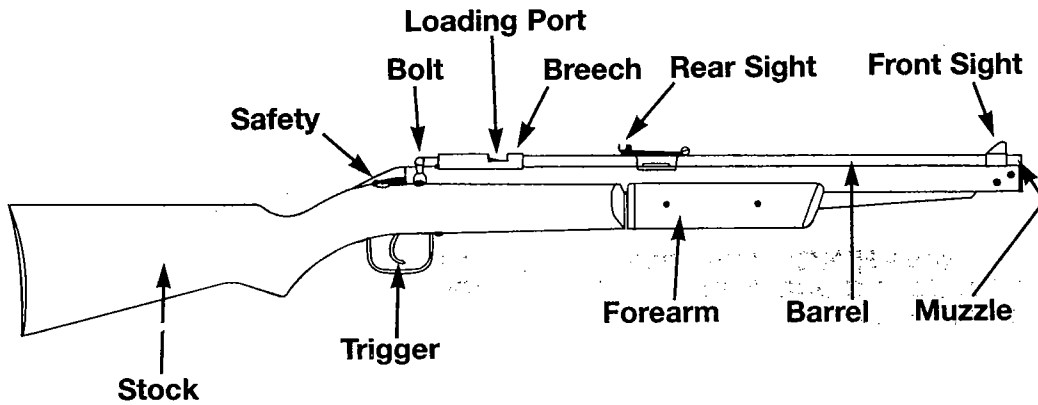

4

Step 2. Operating the Safety

NOTE: BE SURE THE RIFLE IS "OFF SAFE" BEFORE COCKING (Fig. 2). FAILURE TO FOLLOW THE PROCEDURE LISTED BELOW MAY RESULT IN JAMMING THE FIRING MECHANISM.

A. Cocking the Air Rifle

- Point the rifle in a safe direction.
- Push bolt handle up and then pull it all the way to the rear. (Fig. 1)
- Close the bolt by pushing the bolt forward and then downward into the locked position.

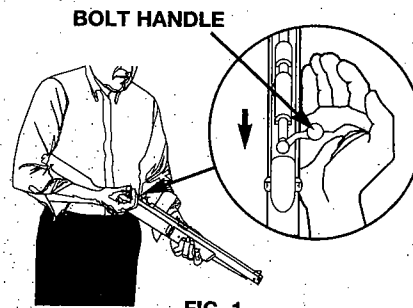

FIG. 1

B. Putting the Air Rifle "On Safe"

⚠ WARNING: THE RIFLE MUST BE COCKED BEFORE YOU CAN PUT IT "ON SAFE." (Fig. 2)

- To put the air rifle "On Safe", push down firmly on the right thumb button marked "S".
- Even when the safety is "On Safe" you should continue to handle the rifle safely. Don't point the rifle at anything you don't intend to shoot.
- To take the air rifle "Off Safe", push down on the left thumb button marked "F". The airgun is now ready to be fired. (Fig.2)

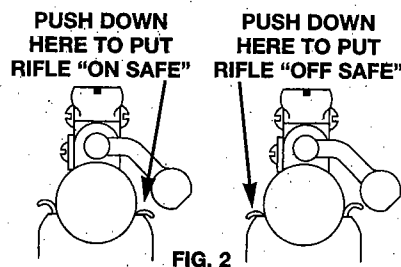

FIG. 2

⚠ WARNING: KEEP THE AIR RIFLE "ON SAFE" UNTIL YOU ARE ACTUALLY READY TO SHOOT. THEN PUSH IT TO "OFF SAFE."

Step 3. Pumping the Air Rifle

- A. Put the rifle "On Safe." (Step 2)
- B. Open the forearm all the way until it stops. (Fig. 3) Close it with a smooth stroke using the heel of your hand. Don't pinch hand or fingers when the forearm closes. Keep your finger off the trigger while pumping.
- C. Be sure to use at least 2 pumps to prevent the barrel from jamming with a pellet.
- D. Do not twist forearm while pumping. Use straight strokes to prevent breakage.

⚠ WARNING: NEVER PUMP YOUR GUN MORE THAN EIGHT TIMES. OVER PUMPING GIVES ONLY A SLIGHT INCREASE IN POWER AND WILL CAUSE MAJOR DAMAGE TO YOUR GUN. PUMPING MORE THAN EIGHT TIMES MAY ALSO LEAVE A SMALL AMOUNT OF AIR IN THE GUN WHICH MAY ALLOW YOU TO FIRE A SECOND SHOT WITHOUT ADDITIONAL PUMPING.

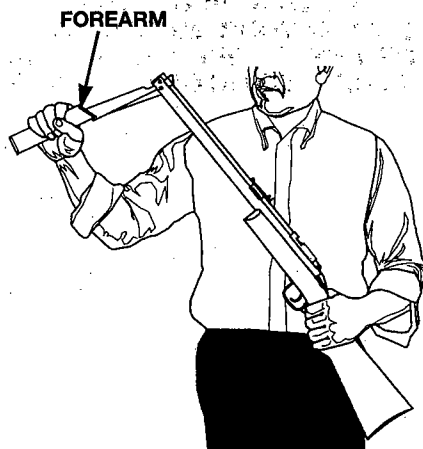

FIG. 3

6

Step 4. Loading and Unloading Pellets

⚠ CAUTION: USE .177 CALIBER PELLETS ONLY IN YOUR MODEL 397C AIR RIFLE. USE OF ANY OTHER AMMUNITION CAN CAUSE INJURY TO YOU OR DAMAGE TO YOUR RIFLE.

A. Loading Pellets

- Put the rifle "On Safe." (Step 2)
- Point the rifle in a safe direction.
- Pull the bolt all the way back. (Step 2A)
- Place one pellet, nose forward, in the loading port (breech). (Fig. 4)
- Lightly push the pellet into the barrel by closing and locking the bolt. DO NOT jam the bolt forward. This will damage your rifle.
- Be sure the bolt is closed before firing. If it is not closed and fully locked, air may remain in the rifle and the pellet may not be discharged.

B. Unloading Pellets

- Put the rifle "On Safe." (Step 2)
- Pump the rifle 8 times, aim in a SAFE DIRECTION, take "Off Safe" and fire.
- Another way of unloading your rifle is to follow the directions listed under Step 6 - Removing a Jammed Pellet.

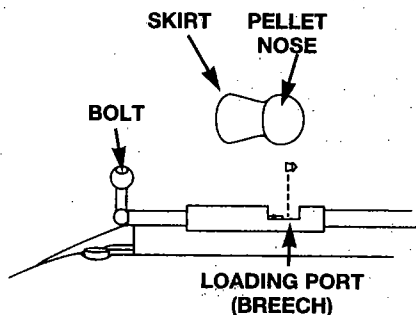

FIG. 4